

# H&S

## HD II RAKE

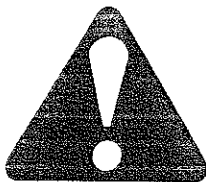
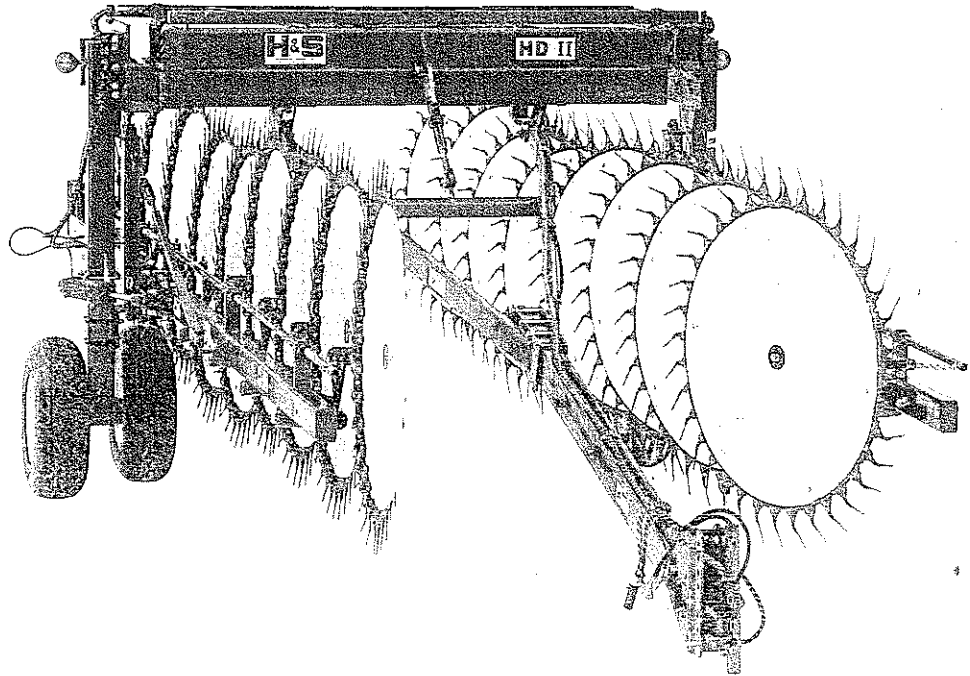

### WARNING

READ AND UNDERSTAND THIS MANUAL  
BEFORE OPERATING THIS EQUIPMENT

UNSAFE OPERATION OR MAINTENANCE OF THIS EQUIPMENT CAN RESULT IN  
SERIOUS INJURY OR DEATH

## OPERATOR'S MANUAL AND PARTS LIST

HSMFG20107

Manufactured By  
**H&S MANUFACTURING CO., INC.**

P.O. BOX 768 (715) 387-3414 FAX (715) 384-5463  
MARSHFIELD, WISCONSIN 54449

FIGURE 1

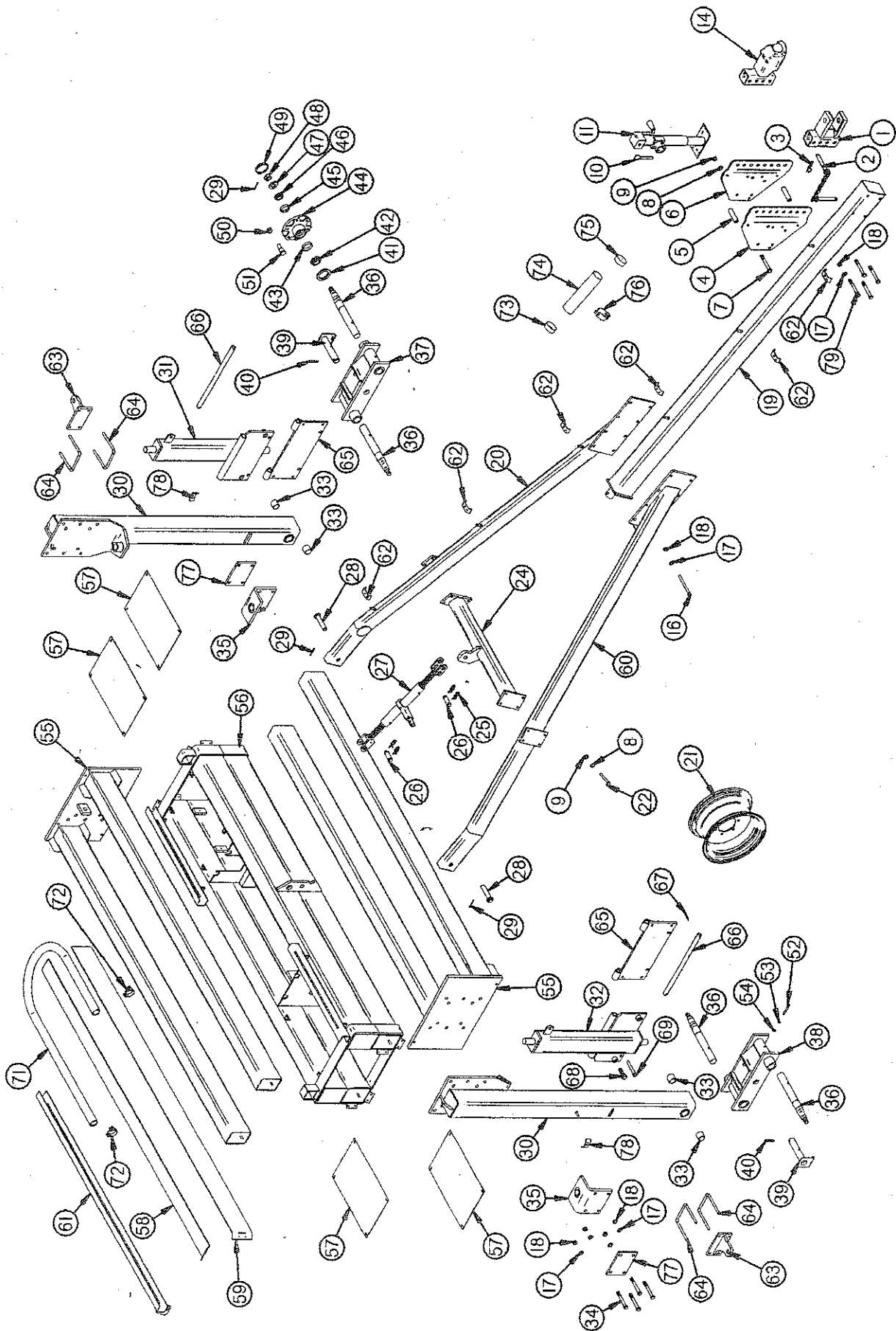

**FIGURE 1**  
**H & S HD II RAKE**  
**MAIN FRAME**

ITEM	PART NO.	DESCRIPTION	ITEM	PART NO.	DESCRIPTION
1.	HD83	Hitch Clevis	44.	RG101	Hub
2.	BFR450	Hitch Pin	45.	RG47	Outer Race
3.	ES7	Hair Pin	46.	RG48	Outer Bearing
4.	HD84	Hitch Mount Right	47.	HD200	Washer
5.	HD85	Hitch Mount Spacer	48.	RG105	Nut
6.	HD86	Hitch Mount Left	49.	RG103	Dust Cap
7.	BFR405	1/2" x 5-1/2" Bolt GR.5	50.	BFR144	Lug Nut
8.	R35	Lock Washer	51.	RG102	Stud Bolt
9.	R29	1/2" Nut	52.	DWM172	3/8" x 3-1/2" Bolt GR.5
10.	BFR4	Jack Pin & Chain	53.	B68	3/8" Lock Washer
11.	BFR223	Jack	54.	K60	3/8" Nut
14.	HD172	Ball Coupler (Optional)	55.	HD103	Inner Slider LH
16.	HD88	5/8" x 6" Bolt GR.5	*	HD205	Inner Slider RH
17.	T69	5/8" Lock Washer	56.**	HD104	Center Slider Outside
18.	T68	5/8" Nut	***	HD183	Center Slider Outside
19.	HD89	Pole Front	57.	HD105	Shield
20.	HD90	Pole Back Left	58.	HD106	Poly Slide Narrow 1/4"
21.	12N24	Wheel 8 x 15	59.	HD107	Poly Slide Wide 1/4"
*	RG128	Tire 9.5L x 15	*	HD155	Poly Slide Narrow 3/16"
22.	LW123	1/2" x 3-3/4" Bolt GR.5	*	HD156	Poly Slide Wide 3/16"
24.	HD92	Jack Mount Tube	60.	HD108	Pole Back Right
25.	T144	Hair Pin	61.**	HD140	Hose Channel
26.	T143	Jack Pin	***	HD184	Hose Channel
27.	T138	Ratchet Jack	62.	23N67	Hose Bracket
28.	HD93	Pole Pivot Pin	63.	HD151	Cylinder Mount Upright End
29.	T72	5/32" x 1-1/2" Cotter Pin	64.	HD152	1/2" U-Bolt
30.	HD94	Axle Upright	65.	HD164	Beam Pivot Plate
31.	HD95	Beam Pivot Left	66.	HD165	Hinge Pin
32.	HD96	Beam Pivot Right	67.	3G22	5/16" x 1-3/4" Expansion Pin
33.	HD153	Bushing	68.	HD166	3/4" x 2-1/2" Bolt GR.5
34.	HD181	5/8" x 7" Bolt GR.5	69.	HD167	5/8" x 3-1/2" Bolt GR.5
35.	HD98	Upright Bottom Pivot	71.**	HD169	Hose Shield
36.	HD99	Spindle	***	HD185	Hose Shield
37.	HD100	Tandem Axle Left	72.**	HD170	Hose Clamp (Size 40)
38.	HD101	Tandem Axle Right	***	HD186	Hose Clamp (Size 48)
39.	HD102	Tandem Pin	73.	S414	Cap
40.	12V59	3/8" x 2-3/4" Roll Pin	74.	S415	Manual Holder Tube
41.	RG98	Seal	75.	S418	Cap w/hole
42.	RG99	Inner Bearing	76.	S416	Manual Hanger Clamp
43.	RG100	Inner Race	77.	HD182	Pivot Mount Plate
<b>NOTE: * (MEANS NOT SHOWN)</b>			78.	HE42	Hose Clamp
<b>** (USED SERIAL #0032 AND BEFORE)</b>			79.	HD208	5/8" x 5-1/2" Bolt GR. 5
<b>*** (USED SERIAL #0033 AND AFTER)</b>					

FIGURE 2

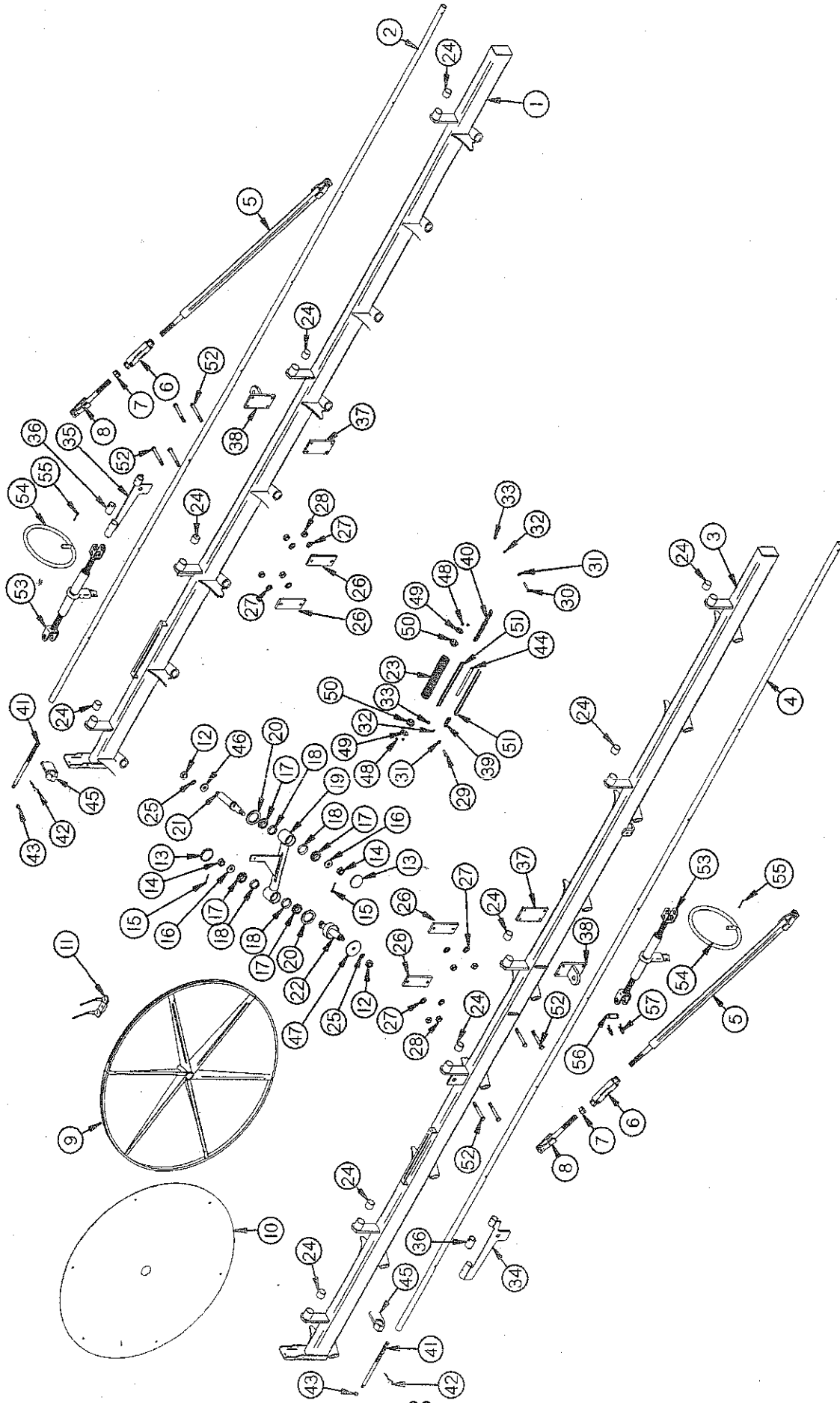

**FIGURE 2**  
**H & S HD II RAKE**  
**RAKE BEAMS**

ITEM	PART NO.	DESCRIPTION	ITEM	PART NO.	DESCRIPTION
1.	HD109	Rake Beam Left	28.	T60	5/8" Lock Nut
2.	HD110	Lifting Pipe Left	29.	17G141	3/8" x 1-1/4" Bolt GR.5
3.	HD111	Rake Beam Right	30.	T123	3/8" x 2-1/4" Bolt GR.5
4.	HD112	Lifting Pipe Right	31.	X67	3/8" Flat Washer
5.	HD113	Stabilizer Tubing	32.	B68	3/8" Lock Washer
6.	HD114	Turnbuckle	33.	K93	3/8" Lock Nut
7.	HD115	Jam Nut	34.	HD130	Lifting Cylinder Mount Right
8.	HD116	Turnbuckle End	35.	HD131	Lifting Cylinder Mount Left
9.	HD117	Rake Wheel	36.	HD175	Lifting pipe Collar
*	HD203	Complete LH Rake Wheel	37.	HD91	Stand Off Mounting Plate
*	HD204	Complete RH Rake Wheel	38.	HD132	Cylinder Mount.
10.	HD118	Wind Guard	39.	HD214	Rake Wheel Short Chain
11.	HD119	Rake Tooth	40.	HD210	Rake Wheel Chain
12.	HD120	3/4" Nut	41.	HD154	Acme Rod
13.	RG103	Dust Cap	42.	BFR137	Hair Pin
14.	RG82	7/8" Nut	43.	R29	1/2" Nut
15.	T172	5/32" x 1-1/2" Cotter Pin	44.	HD179	Spring Stopper
16.	HD121	7/8"ID x 1-3/4" OD Washer	45.	BFR426	Rake Pressure Handle
17.	HD122	Bearing	46.	HD157	Pivot Washer
18.	3G18	Bearing Race	47.	HD158	Spindle Washer
19.	HD123	Rake Arm	48.	D65	1/4" Lock Nut
20.	HD124	Seal	49.	HD176	Spring Holder Washer
21.	HD125	Pivot Spindle	50.	HD177	Poly Spring Holder
22.	HD126	Rake Wheel Spindle	51.	HD178	Torsion Bar
23.	HD127	Spring	52.	HD174	5/8" X 5" Bolt GR. 5
*	HD201	Complete Spring Assembly	<b>ITEMS 53-57 USED ON MANUAL MODEL ONLY</b>		
24.	HD128	Bushing	53.	T138	Ratchet Jack
25.	RG113	Star Washer	54.	HD213	Handle Band
26.	HD202	Beam Plate	55.	R70	3/16" x 2" Cotter Pin
27.	T69	5/8" Lock Washer	56.	T143	Jack Pin
<b>NOTE: * (MEANS NOT SHOWN)</b>			57.	T144	Hair Pin

FIGURE 3

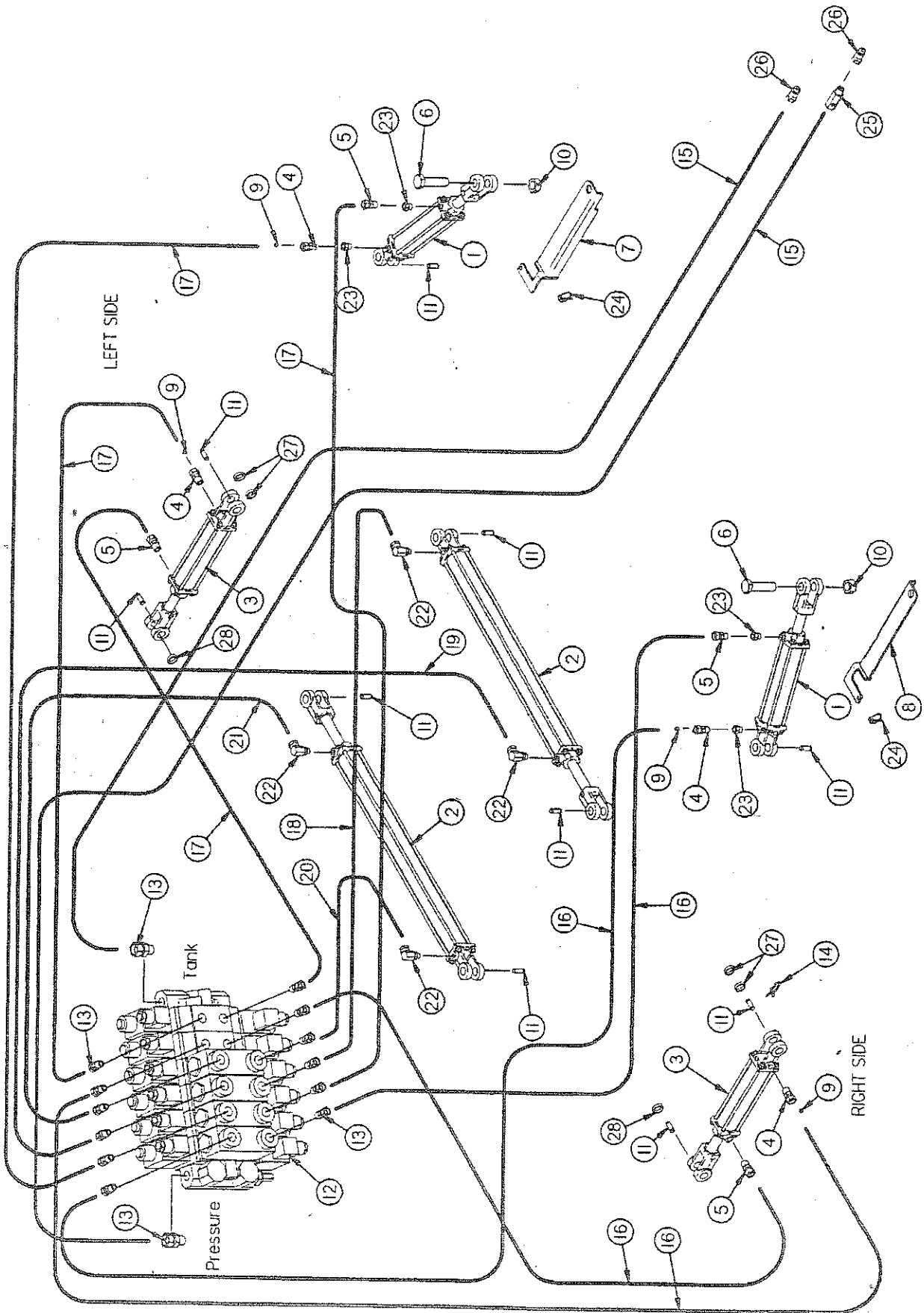

**FIGURE 3  
H & S HD II RAKE  
HYDRAULICS**

<b>ITEM</b>	<b>PART NO.</b>	<b>DESCRIPTION</b>
1.	HD135	Hydraulic Cylinder 3" x 8"
2.	HD136	Hydraulic Cylinder 3-1/2" x 60"
3.	16SV171	Hydraulic Lift Cylinder 2" x 10"
4.	BFR122	3/8" Union Adapter
5.	DWM233	3/8" Union Adapter
6.	BFR177	1" x 4" Bolt GR.5
7.	HD137	Transport Lock Left
8.	HD138	Transport Lock Right
9.	BFR120	.062 Orifice
10.	BFR178	1" Lock Nut
11.	T143	Hydraulic Cylinder Pin
12.	HD139	Hydraulic Valve
13.	DWM268	9/16" Male O-Ring to 3/8" Pipe Union Adapter
14.	T144	Cylinder Pin Clip
15.	HD141	Hydraulic Hose 3/8" x 288" 1/2"MP & 3/8"MP
16.	HD142	Hydraulic Hose 1/4" x 288" 3/8"MP & 3/8"MP
17.	HD143	Hydraulic Hose 1/4" x 210" 3/8"MP & 3/8"MP
18.	HD144	Hydraulic Hose 1/4" x 36" 3/8"MP & 1/2"MP
19.	HD145	Hydraulic Hose 1/4" x 96" 3/8"MP & 1/2"MP
20.	HD147	Hydraulic Hose 1/4" x 60" 3/8"MP & 1/2"MP
21.	HD146	Hydraulic Hose 1/4" x 20" 3/8"MP & 1/2"MP
22.	WM175	1/2" 90° Union Adapter
23.	JB82	Bushing 1/2" to 3/8"
24.	BFR443	Clip Pin
25.	DF18	1/2" Check Valve
26.	DWM205	1/2" Male Quick Coupler
27.	X94	Spacer 5/16" x 1"
28.	HD187	Spacer 3/4" x 1"

FIGURE 4

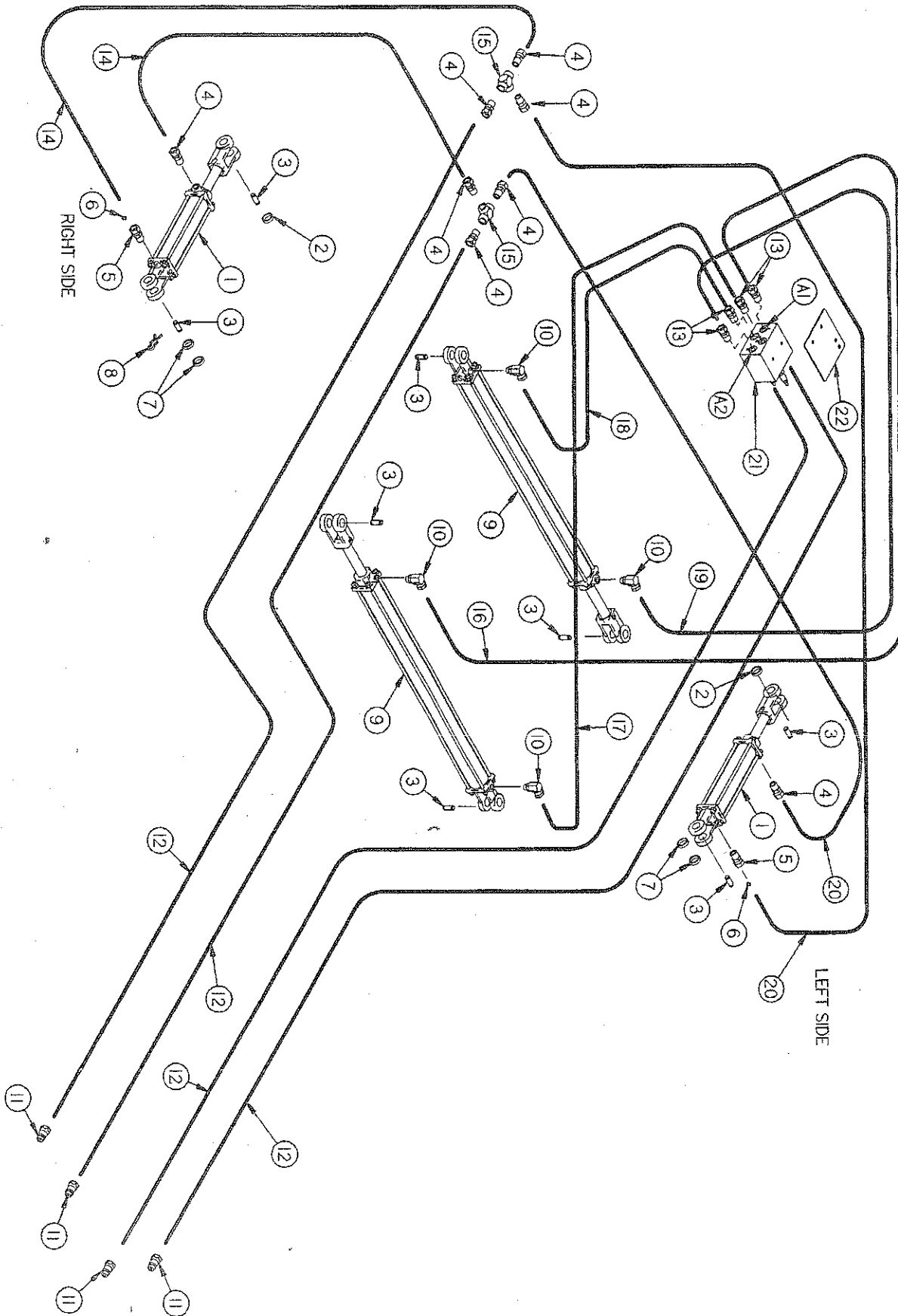
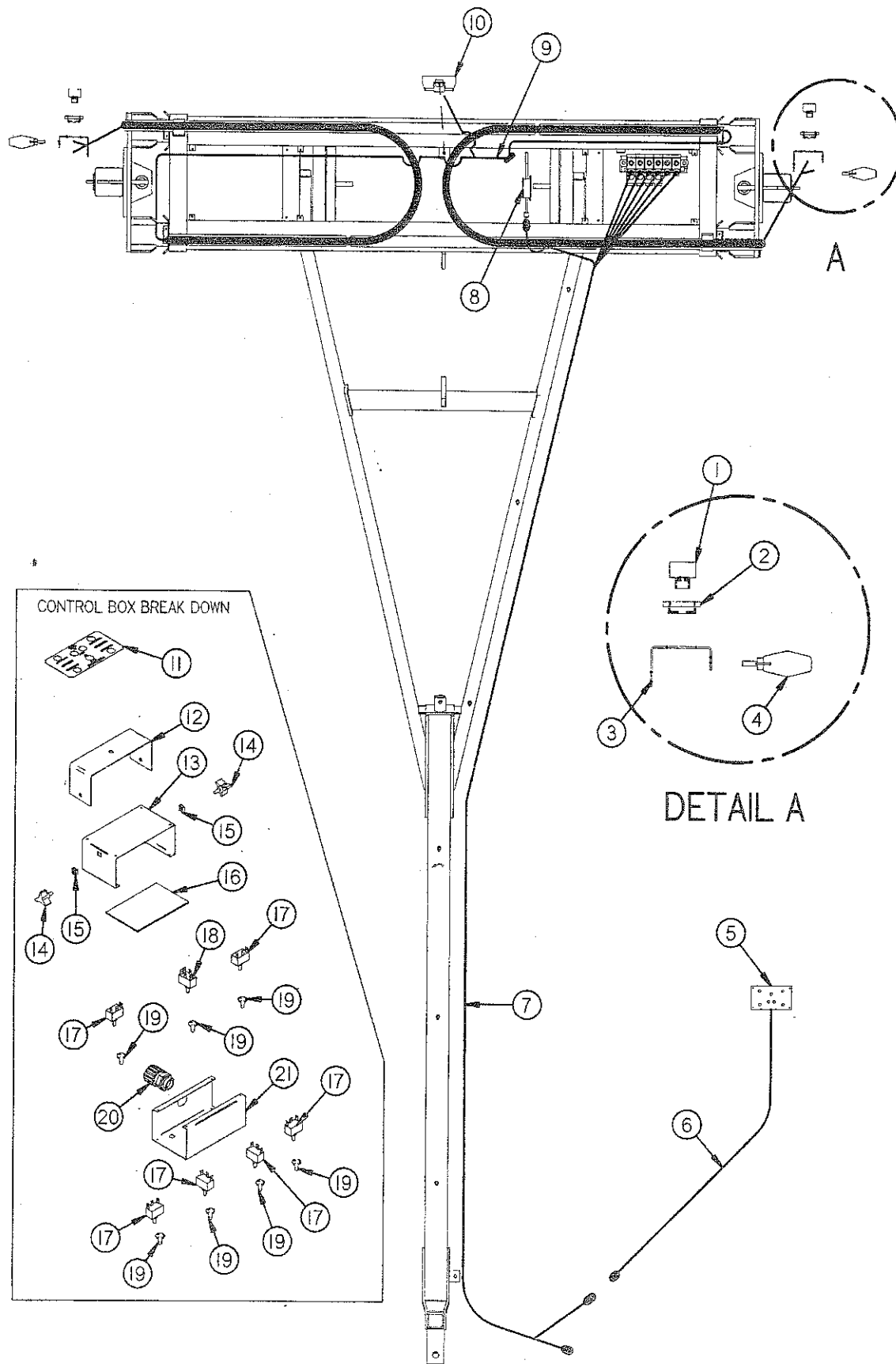



**FIGURE 4**  
**H & S HD II RAKE**  
**HYDRAULICS (MANUAL MODEL)**

<b>ITEM</b>	<b>PART NO.</b>	<b>DESCRIPTION</b>
1.	16SV171	Hydraulic Lift Cylinder 2" x 10"
2.	HD187	3/4" x 1" Spacer
3.	T143	Hydraulic Cylinder Pin
4.	DWM233	3/8" Union Adapter
5.	BFR122	3/8" Union Adapter
6.	BFR120	.062 Orifice
7.	X94	5/16" x 1" Spacer
8.	T144	Cylinder Clip Pin
9.	HD136	Hydraulic Cylinder 3-1/2" x 60"
10.	WM175	1/2" 90° Union Adapter
11.	DWM205	1/2" Male Quick Coupler
12.	HD141	3/8" x 288" Hose 1/2"MP & 3/8"MP
13.	DWM269	Boss Union Adapter
14.	HD142	1/4" x 288" Hose 3/8"MP & 3/8"MP
15.	BFR74	3/8" Female Tee
16.	HD145	1/4" x 96" Hose 3/8"MP & 1/2"MP
17.	HD144	1/4" x 36" Hose 3/8"MP & 1/2"MP
18.	HD147	1/4" x 60" Hose 3/8"MP & 1/2"MP
19.	HD146	1/4" x 20" Hose 3/8"MP & 1/2"MP
20.	HD143	1/4" x 210" Hose 3/8"MP & 3/8"MP
21.	XR100	Flow Divider Valve
22.	HD212	Valve Mount

FIGURE 5



**FIGURE 5**  
**H & S HD II RAKE**  
**WIRING**

<b>ITEM</b>	<b>PART NO.</b>	<b>DESCRIPTION</b>
1.	S310	Red Tail Light
2.	S308	Rubber Light Mount
3.	HD148	Light Bracket
4.	DWM129	Yellow Hazard Light
5.	HD149	Complete Control Box w/Harness
6.	HD160	Control Box Whip
7.	HD161	Main Harness
8.	S441	Light Module
9.	HD149	Tail Light Loom
10.	DWM130	Flood/Work Light
11.	61003	Control Box Decal
12.	DWM326	Control Box Mount
13.	DWM140	Control Box Bottom
14.	HD174	Knob
15.	HD173	Panel Nut
16.	HD163	Poly Shield
17.	HD207	Momentary Switch
18.	HD159	Master Switch
19.	16SV235	Switch Boot
20.	DWM175	Strain Relief (Cord Grip)
21.	HD150	Control Box Top

FIGURE 6

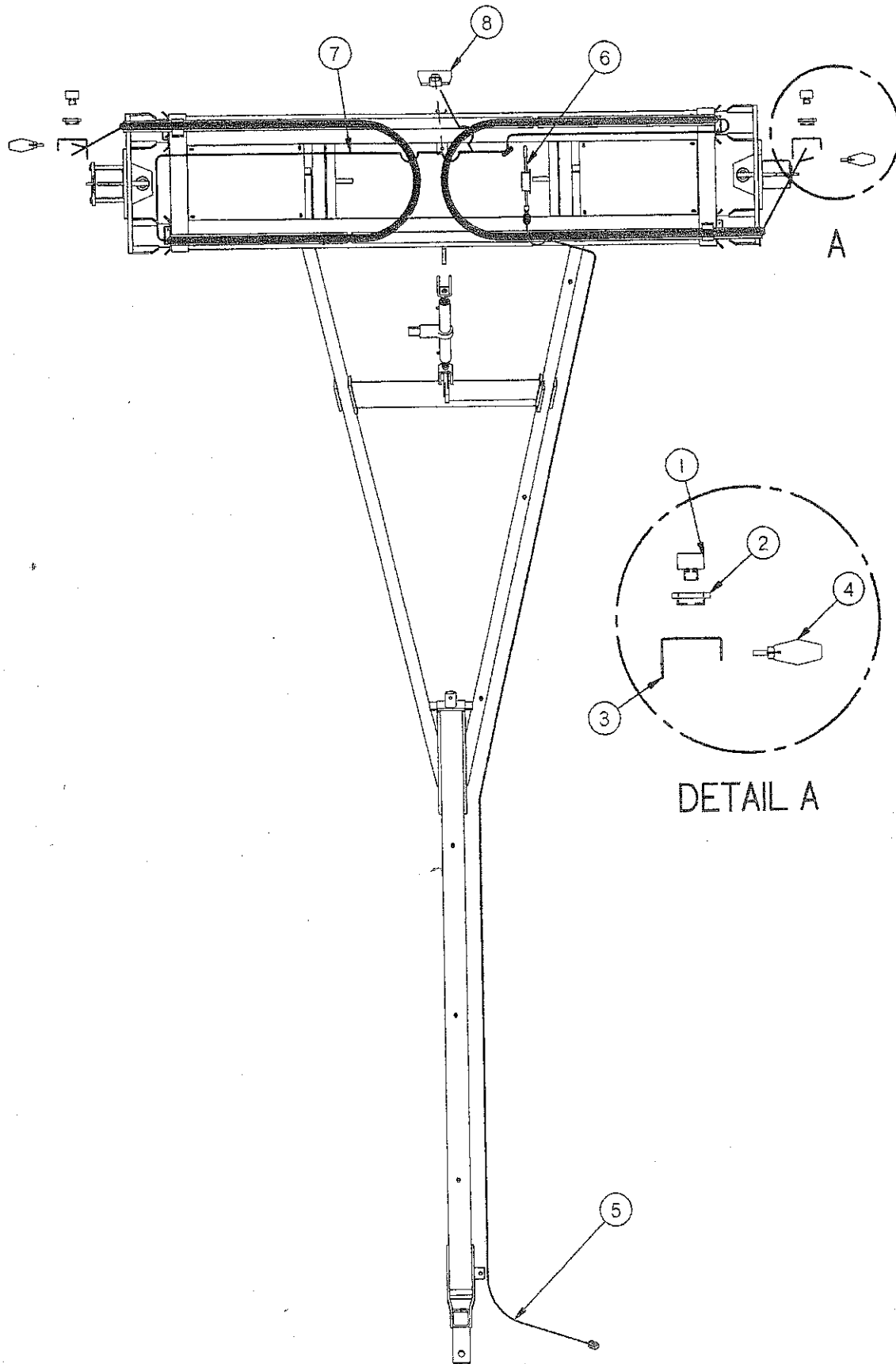

**FIGURE 6**  
**H & S HD II RAKE**  
**WIRING (MANUAL MODEL)**

<b>ITEM</b>	<b>PART NO.</b>	<b>DESCRIPTION</b>
1.	S310	Red Tail Light
2.	S308	Rubber Light Mount
3.	HD148	Light Bracket
4.	DWM129	Yellow Hazard Light
5.	MHD1	Front Light Loom
6.	S441	Light Module
7.	HD149	Tail Light Loom
8.	DWM130	Work Light

FIGURE 7

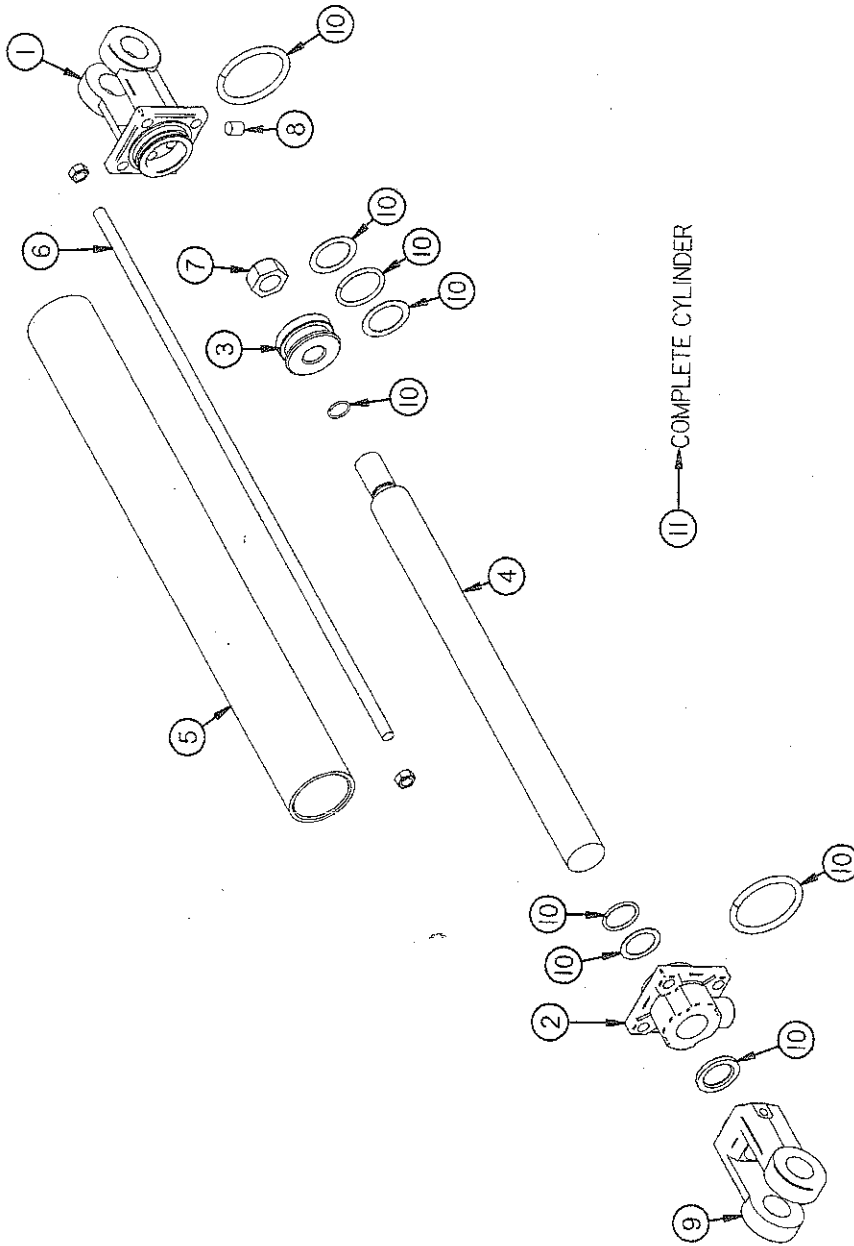

**FIGURE 7  
H&S HD II RAKE  
HYDRAULIC CYLINDERS**

	<b>LIFT CYLINDER 2" x 10"</b>	<b>WING CYLINDER 3" x 8"</b>	<b>FRAME WIDTH 3-1/2" x 60"</b>	
<b>ITEM</b>	<b>PART NO.</b>	<b>PART NO.</b>	<b>PART NO.</b>	<b>DESCRIPTION</b>
1.	23N142A	DWM192	16SV157A	Clevis Cap
2.	23N143A	HD188	HD189	Rod Cap
3.	23N144	DWM194	HD198	Piston
4.	16SV168A	HD190	HD191	Rod
5.	16SV169	HD192	HD193	Cylinder Tube
6.	16SV170	HD194	HD195	Tie Rod
7.	23N148	DWM198	DWM198	Piston Nut
8.	23N149	DWM199	DWM199	Plug
9.	23N150A	DWM200	DWM200	Rod Clevis
10.	23N151	HD196	HD197	Seal Kit
11.	16SV171	HD135	HD136	Hydraulic Cylinder

FIGURE 8

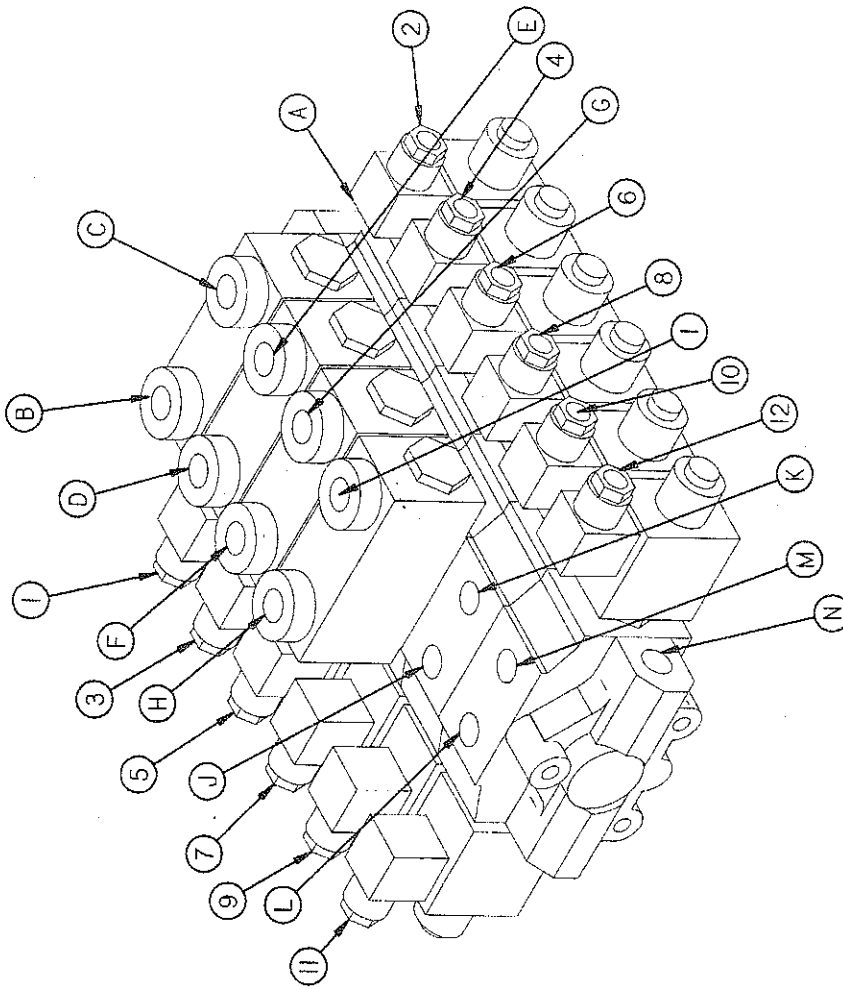

- DIN # 1
- DIN # 2
- DIN # 3
- DIN # 4
- DIN # 5
- DIN # 6
- DIN # 7
- DIN # 8
- DIN # 9
- DIN # 10
- DIN # 11
- DIN # 12

- PRESSURE PORT
- RIGHT BEAM OPEN
- RIGHT BEAM CLOSED
- LEFT BEAM OPEN
- LEFT BEAM CLOSED
- RIGHT WIDTH OUT
- RIGHT WIDTH IN
- LEFT WIDTH OUT
- LEFT WIDTH IN
- RIGHT RAKE WHEEL UP
- RIGHT RAKE WHEEL DOWN
- LEFT RAKE WHEEL UP
- LEFT RAKE WHEEL DOWN
- TAND PORT



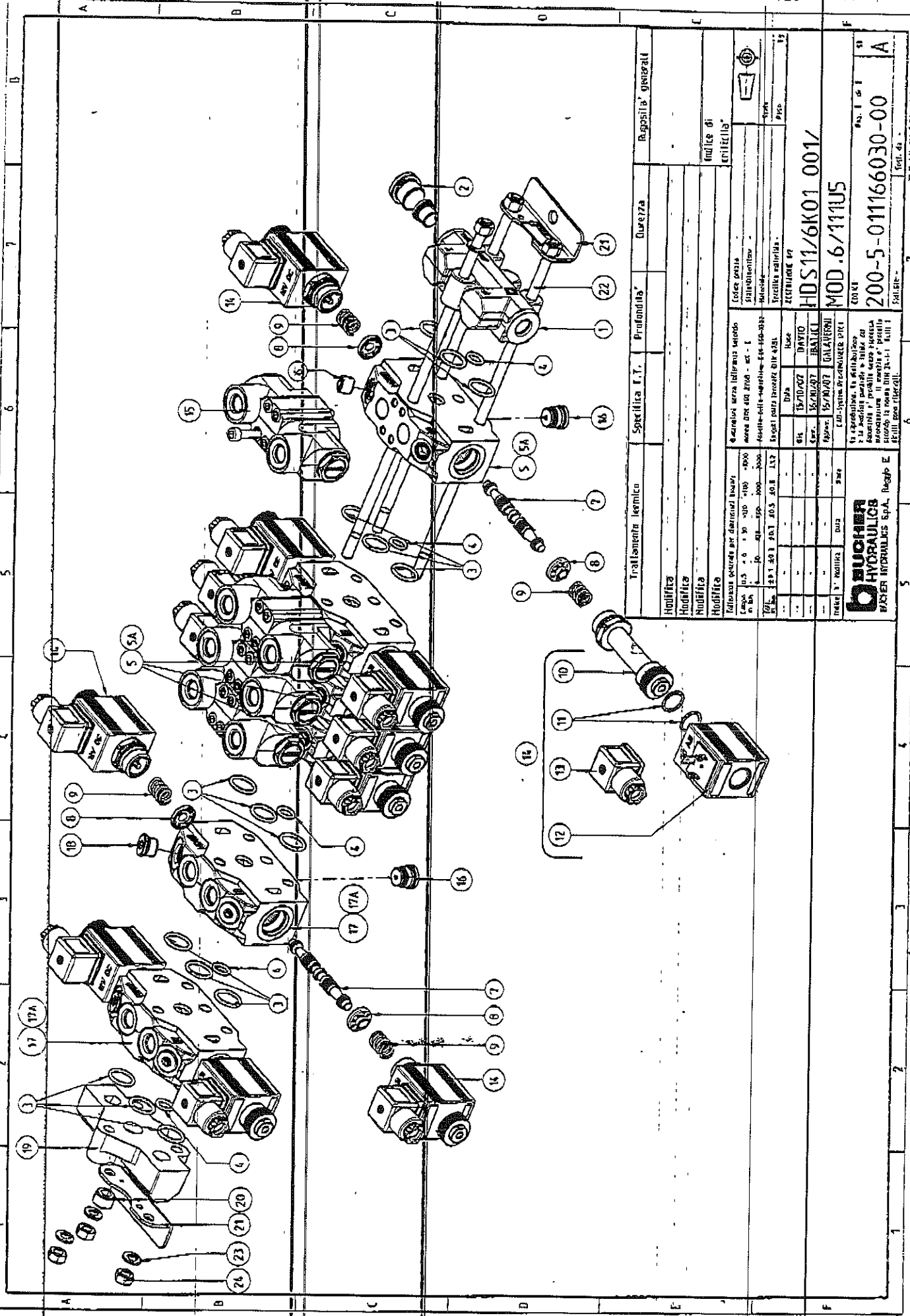

Trattamento termico	Specifica T.T.	Profondità	Durezza	Rappresentazione
Non trattata				
Non trattata				
Non trattata				
Non trattata				
<p>Indicazioni generali per dimensionamento:</p> <p>Tempo: 0,5 - 0,50 - 0,100 - 0,200 - 0,400 - 0,800 - 1,600 - 3,200 - 6,400 - 12,800 - 25,600 - 51,200 - 102,400 - 204,800 - 409,600 - 819,200 - 1638,400 - 3276,800 - 6553,600 - 13107,200 - 26214,400 - 52428,800 - 104857,600 - 209715,200 - 419430,400 - 838860,800 - 1677721,600 - 3355443,200 - 6710886,400 - 13421772,800 - 26843545,600 - 53687091,200 - 107374182,400 - 214748364,800 - 429496729,600 - 858993459,200 - 1717986918,400 - 3435973836,800 - 6871947673,600 - 13743895347,200 - 27487790694,400 - 54975581388,800 - 109951162777,600 - 219902325555,200 - 439804651110,400 - 879609302220,800 - 1759218604441,600 - 3518437208883,200 - 7036874417766,400 - 14073748835532,800 - 28147497671065,600 - 56294995342131,200 - 112589990684262,400 - 225179981368524,800 - 450359962737049,600 - 900719925474099,200 - 1801439850948198,400 - 3602879701896396,800 - 7205759403792793,600 - 14411518807585587,200 - 28823037615171174,400 - 57646075230342348,800 - 115292150460684697,600 - 230584300921369395,200 - 461168601842738790,400 - 922337203685477580,800 - 1844674407370955161,600 - 3689348814741910323,200 - 7378697629483820646,400 - 14757395258967641292,800 - 29514790517935282585,600 - 59029581035870565171,200 - 118059162071741130342,400 - 236118324143482260684,800 - 472236648286964521369,600 - 944473296573929042739,200 - 1888946593147858085478,400 - 3777893186295716170956,800 - 7555786372591432341913,600 - 15111572745182864683827,200 - 30223145490365729367654,400 - 60446290980731458735308,800 - 120892581961462917470617,600 - 241785163922925834941235,200 - 483570327845851669882470,400 - 967140655691703339764940,800 - 1934281311383406679529881,600 - 3868562622766813359059763,200 - 7737125245533626718119526,400 - 15474250491067253436239052,800 - 30948500982134506872478105,600 - 618970019642690137449562112,000 - 1237940039285380274899124224,000 - 2475880078570760549798248448,000 - 4951760157141521099596496896,000 - 9903520314283042199193993792,000 - 19807040628566084398387987584,000 - 39614081257132168796775975168,000 - 79228162514264337593551950336,000 - 158456325028528675187103900672,000 - 316912650057057350374207801344,000 - 633825300114114700748415602688,000 - 1267650600228229401496831205376,000 - 2535301200456458802993662410752,000 - 5070602400912917605987324821504,000 - 10141204801825835211974649643008,000 - 20282409603651670423949299286016,000 - 40564819207303340847898598572032,000 - 81129638414606681695797197144064,000 - 162259276829213363391594394288128,000 - 324518553658426726783188788576256,000 - 649037107316853453566377577152512,000 - 1298074214633706907132755154305024,000 - 2596148429267413814265510308610048,000 - 5192296858534827628531020617220096,000 - 10384593717069655257062041234440192,000 - 20769187434139310514124082468880384,000 - 41538374868278621028248164937760768,000 - 83076749736557242056496329875521536,000 - 166153499473114484112992659751042672,000 - 33230699894622896822598531950205344,000 - 66461399789245793645197063900410688,000 - 132922799578491587290394127800821376,000 - 265845599156983174580788255601642752,000 - 531691198313966349161576511203285504,000 - 1063382396627932698323153022406571008,000 - 2126764793255865396646306044813142016,000 - 42535295865117307932926120896262842304,000 - 85070591730234615865852241792525684608,000 - 17014118346046923173170448358505137216,000 - 34028236692093846346340896717010274432,000 - 68056473384187692692681793434020548864,000 - 136112946768375385385363586868041097312,000 - 272225893536750770770727173736082194624,000 - 544451787073501541541454347472164389248,000 - 108890357414700308308290869494432877856,000 - 217780714829400616616581738988865755712,000 - 435561429658801233233163477977731511424,000 - 871122859317602466466326955955463022848,000 - 1742245718635204932932653911910266055696,000 - 3484491437270409865865307823820532111392,000 - 6968982874540819731730615647641064222784,000 - 1393796574908163946346123129528212455568,000 - 27875931498163278926922462590564251111136,000 - 5575186299632655785384492518112850222272,000 - 11150372599265311570768985036225704444544,000 - 22300745198530623141537970072451408888896,000 - 44601490397061246283075940144902777777792,000 - 8920298079412249256615188028980555555584,000 - 17840596158824498513230376057961111111667,000 - 3568119231764899702646075211592222222334,000 - 713623846352979940529215043118444444668,000 - 1427247692705959881058430086236888893376,000 - 2854495385411919762116860722473777776752,000 - 5708990770823839524233721444947555551504,000 - 11417981541647679048467442889895111111008,000 - 22835963083295358096934885779790222222016,000 - 45671926166590716193869771559580444444032,000 - 91343852333181432387739543119160888888864,000 - 182687704666362864775479086238321777777128,000 - 365375409332725729550958172476643555555256,000 - 7307508186654514591019163449532871111110512,000 - 146150163733090291820383268990654222222201024,000 - 292300327466180583640766537981308444444402048,000 - 584600654932361167281533075962616888888804096,000 - 116920130986472233456306615192533777777768192,000 - 23384026197294446691261323038506755555536384,000 - 46768052394588893382522646077013511111106768,000 - 93536104789177786765045292154027022222213536,000 - 18707220957835557353009058430805404444427072,000 - 37414441915671114706018116861601080888844144,000 - 748288838313422294120362337230216617777768288,000 - 1496577676626844588240724674460432355555136576,000 - 2993155353253689176481449348920864711111073152,000 - 59863107065073783529628986978417284222221462304,000 - 11972621413014756705925797395683456844442924608,000 - 23945242826029513411851594791366912888885849216,000 - 47890485652059026823703189822733825777771698432,000 - 957809713041180536474063796454676555553396864,000 - 1915619426082361072948127592909353111110793728,000 - 3831238852164722145896255185818706222221587456,000 - 7662477704329444291792510317637412444421174912,000 - 1532495540865888858358502063527482488883349824,000 - 3064991081731777717171004127105484977776698496,000 - 6129982163463555434342008254210969955551339392,000 - 12259964326927110868684016508421939911110678784,000 - 2451992865385422173736803301684387982222213577568,000 - 49039857307708443474736066033687759644442715515136,000 - 980797146154168869494721320673755192888854310272,000 - 19615942922883377389894426413475103857777086244,000 - 392318858457667547797888528269502077155551722488,000 - 784637716915335095595777056539004154311110444976,000 - 1569275433830670191191554113078008288622220889952,000 - 313855086766134038238310822615760167724441779904,000 - 627710173532268076476621652235520335448883559808,000 - 1255420347064536152953233304471040670897771118416,000 - 251084069412907230590646660894208137795552236832,000 - 502168138825814461181293321788416275191110467664,000 - 1004336277651628922362586643576824503822221733312,000 - 2008672555303257844725173287153649000644443466624,000 - 4017345110606515689450346574307280012888886932496,000 - 8034690221213031378900693148614560025777773864992,000 - 16069380442426062757801386297229120051555557729984,000 - 321387608848521255156027725944582400103111111559968,000 - 6427752176970425103120545188891648002062222211199376,000 - 1285550435394085020624109037779200412444442239872,000 - 2571100870788170041248218185558400824888884479744,000 - 514220174157634008249643637111680016977777699488,000 - 1028440348315268016499287274223360033955555138976,000 - 2056880696630536032998574548446720067911111077952,000 - 4113761393261072065997149096893440135822222155904,000 - 8227522786522144131994298193786880271644442111808,000 - 164550455730442882639885963875737605431111035616,000 - 3291009114608857652797719277514752010622221711232,000 - 6582018229217715305595438555029504021244442222464,000 - 13164036458435430611190877110059008042488884444928,000 - 263280729168708612223817542201180160449777768976,000 - 5265614583374172244476350844023603208995555137952,000 - 1053122916674354448895270168804720641991111075904,000 - 21062458333487088977905403376094413982222151808,000 - 421249166669741779558108067521888279644442116016,000 - 842498333339483559116216135043777559288884422032,000 - 168499666667896711823243227008755119777768444064,000 - 336999333335793423646486454017511955555136896,000 - 673998666671586847292972908035039111110737952,000 - 1347997333343173694585945816070078222221467904,000 - 2695994666686347389171891632140156444421193808,000 - 53919893333726947783437832642803128888844227168,000 - 107839786667453895566875665285602577776844453336,000 - 21567957333488791113375133057120555551368672,000 - 4313591466697758222675026611424111110737344,000 - 8627182933515516445350053222848222221467488,000 - 1725436586703103289070010445696444421193496,000 - 345087317340620657814002091139288888442271992,000 - 69017463468124131562800418227857777684445384,000 - 138034926936248263125600836455715555510768,000 - 2760698538724965262512016731114111101536,000 - 5521397077449930525024033462228222210672,000 - 11042794154899661050048067244564444213344,000 - 220855883097993221000961348891288888426688,000 - 4417117661959864420019226977825777753376,000 - 883423532391972884003845395565155555106752,000 - 176684706478394576800768109113031111013344,000 - 353369412956789153601536218226062222106688,000 - 7067388259135783072030724364521244442133376,000 - 14134776518271566144061448729042488884266752,000 - 2826955303654313228812897445808497777533504,000 - 56539106073086264576257949116169955551067008,000 - 1130782121461725291525158982323399111101334016,000 - 22615642429234505830503179666467822221066832,000 - 45231284858469011661006359332935644442133364,000 - 90462569716938023322001270665871288884266768,000 - 1809251394338760466440025413317557777533536,000 - 361850278867752093288005082663511555551067672,000 - 7237005577355041865760101653270222210668144,000 - 1447401115471008373152020330654044442133328,000 - 289480223094201674630404066130808888426656,000 - 578960446188403349260808132261617777533112,000 - 115792089237680669852161626452335555106224,000 - 23158417847536133970432325290471111012448,000 - 4631683569507226794086465058094222210668496,000 - 926336713901445358817293011618444421333992,000 - 185267342780289071763458602323688884266984,000 - 370534685560578143526917204647377775331968,000 - 7410693711211562870538344092947555510673936,000 - 14821387422423125741076688188591111013472,000 - 29642774844846251482153777771798222210668944,000 - 5928554968969250296430755554396444421333888,000 - 11857109937938500592861511110792888842667776,000 - 2371421987587700118572302222158577775331552,000 - 474284397517540023714460444421333211101104,000 - 948568795035080047428920888842664222210668208,000 - 189713759007016009485784177771532444421333416,000 - 3794275180140320189715635555406488884266832,000 - 7588550360280640379431271111013472,000 - 1517710072056128075882542222158577775331552,000 - 303542014411225615176508444421333211101104,000 - 607084028822451231353016888842664222210668208,000 - 121416805764490246270603377771532444421333416,000 - 2428336115289804925412067555406488884266832,000 - 4856672230579609850824135111013472,000 - 9713344461159219701648271111013472,000 - 1942668892231843940329654222158577775331552,000 - 388533778446368788065930844421333211101104,000 - 777067556892737576131861688842664222210668208,000 - 155413511378547515226372337771532444421333416,000 - 3108270227570950304527446755406488884266832,000 - 6216540455141900609054913511013472,000 - 12433080910283801218109827111013472,000 - 24866161820567602436219654222158577775331552,000 - 4973232364113520487243930844421333211101104,000 - 9946464728227040974487861688842664222210668208,000 - 198929294564540819489757233771532444421333416,000 - 39785858912908163977951446755406488884266832,000 - 795717178258163279559028911013472,000 - 15914343565163265591180578222158577775331552,000 - 3182868713032653118236115644421333211101104,000 - 63657374260653062364722313088842664222210668208,000 - 12731474852130612472944462617771532444421333416,000 - 25462949704261224945888925355406488884266832,000 - 50925899408522449891777850711013472,000 - 10185179881704489978355610144421333211101104,000 - 20370359763408979956711220288842664222210668208,000 - 407407</p>				



Spare part list drawing code number 200-5-011166030-00  
HDS11/6K01 001/MOD.6/111U5

Ref	Code	Description	Note	Qty
1	200631060021	HDS 11 T06 P SAE6 RV HEAD		1,000
2	200778400140	PLUG G0VC00 HDM140-HDM10-UP10		1,000
3	200514238511	OR 3068 017.13X2.62 NBR90 HD233		2,000
4	200514237411	OR 112009.92X2.62 NBR90 HD232		7,000
5	200741390200	HDS 11 K263 EMC X VAL.RP BODY	Complete with OR Check Valve and plugs	4,000
5A	200741290061	EL.11 K263 AE01E 13 RP/AB SAE6		4,000
6	200527160201	PLUG CEI 1/4" G DIN 906 ST ZG HD234		8,000
7	200651001022	HDS11 AE D10 EMC TYPE SPOOL		6,000
8	200653201690	SPACER PUSH SPOOL HDS11		12,000
9	200662401800	SPRING FOR ON-OFF HDS11 CONTROL		12,000
10	200706300170	TUBE GM4012 D.16 X HDS11	HD216	12,000
11	200514113810	OR 2062 015.60X1.78 NBR70		24,000
12	200674910050	COIL 012V C35D012DC-30W HC	HD139	12,000
13	200544110009	CONNECTOR MPM18209N ST.3VITI		12,000
14	200774910370	SOLENOID 012V+CANN.HDS11 ON-O		12,000
15	200787602270	RP/A-B SAE6 HDM12 VALVE	Complete code with screws washer and QR	4,000
16	200787601200	CHECK VALVE HDS10 T.N.	HD236	6,000
17	200741260004	EL.11 K201 AE01E 13	HD235	2,000
17A	200741360550	HDS 11 K201 SAE6 EMC BODY	Complete with OR Check Valve and plugs	2,000
18	200527481601	PLUG TCEI 9/16-18UNF SAE6ZG+OR	HD237	4,000
19	200730060030	HDS 11 P13 SAE6 CC COVER		1,000
20	200527107401	PLUG CEI M016X1.50 DIN906ST ZG		1,000
21	200677200421	VALVE BRACKET HDS 11		2,000
22	200683201180	TIE ROD M08X318 R10 20 10.9 D		3,000
23	200530390821	WASHER B 08.2X14.9 DIN128 ZG		4,000
24	200525203551	NUT M08X1.25X8.5 UNI 5588A8GZG		3,000

FIGURE 9

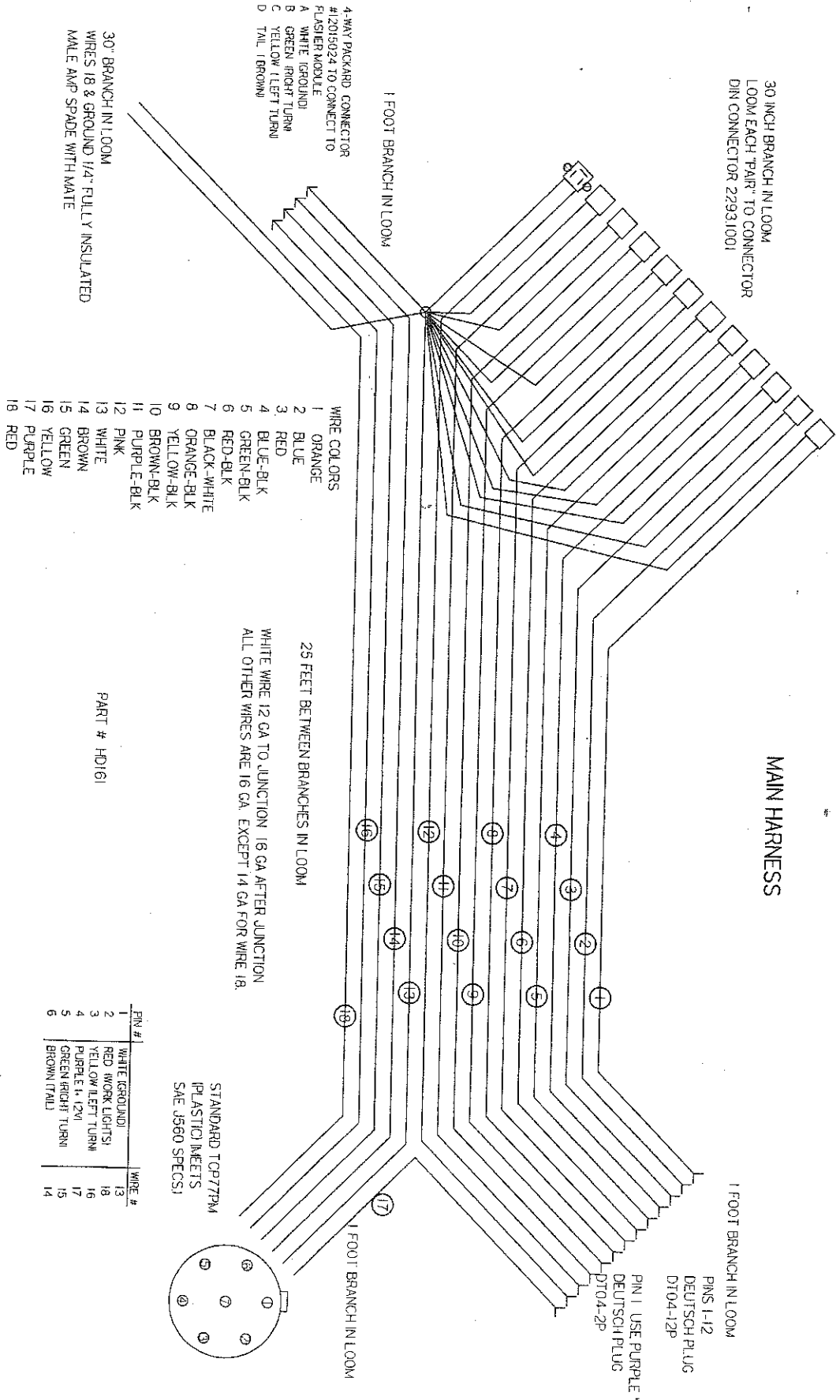

FIGURE 10

CONTROL BOX WHIP

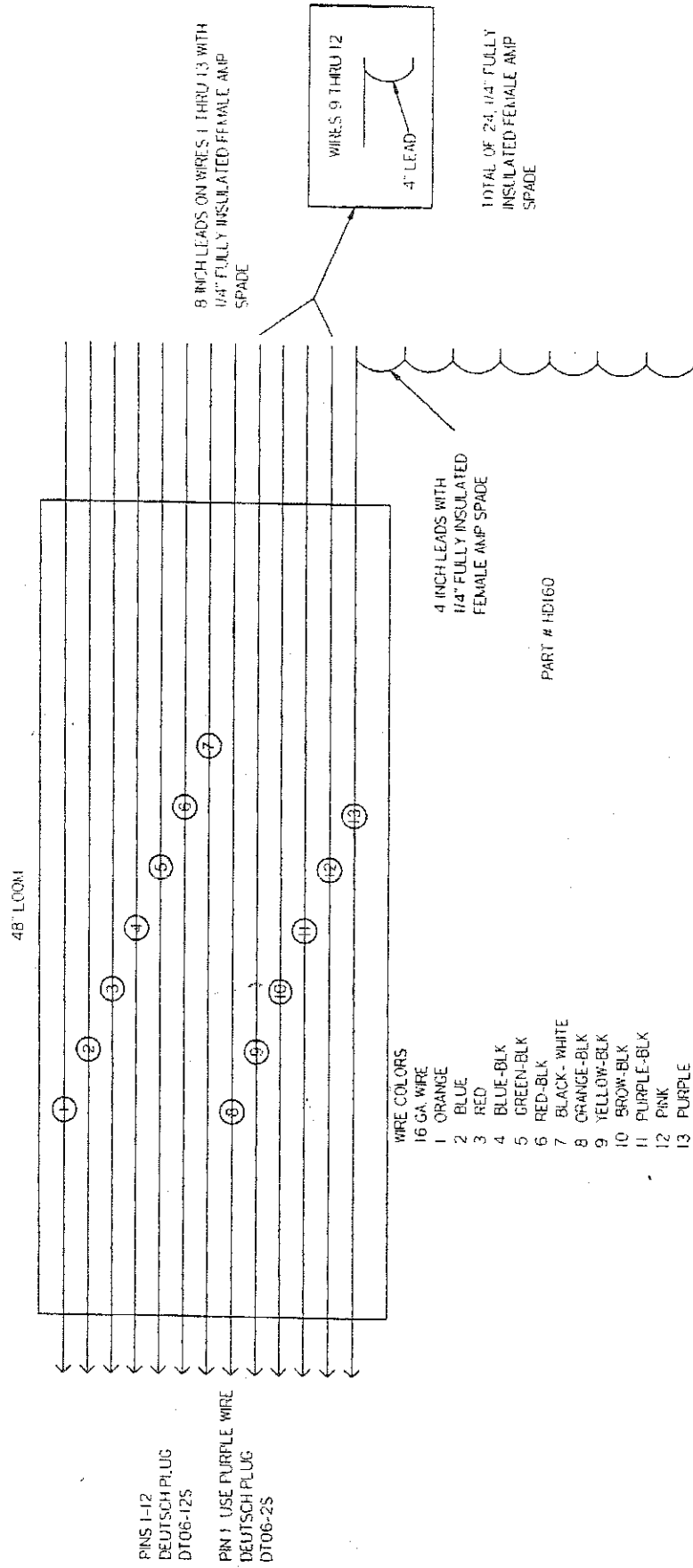
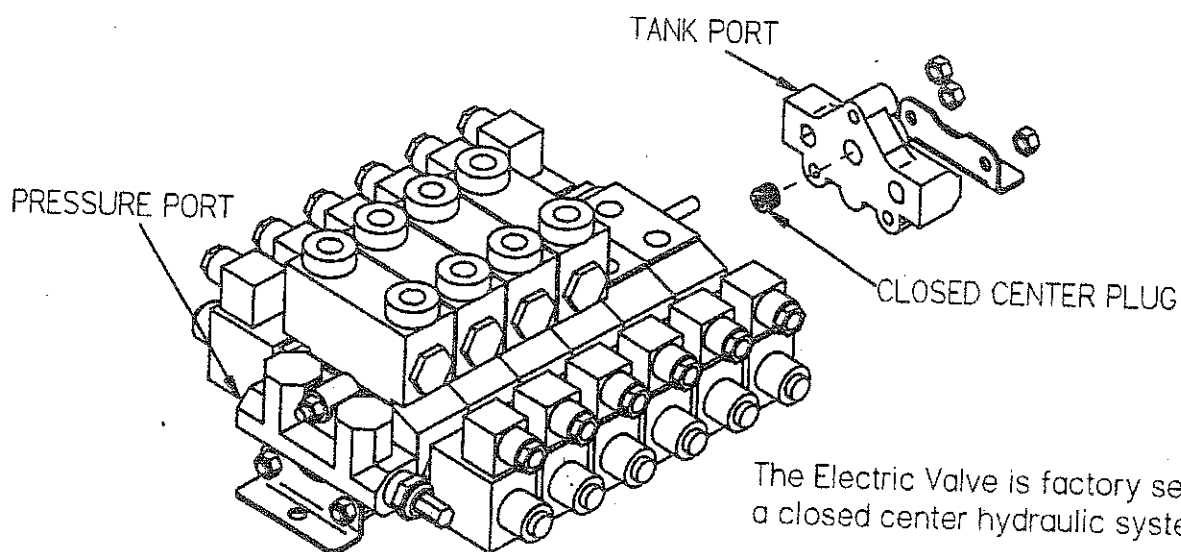

FIGURE 11



If closed center valve is used on a open center tractor it will cause the oil to heat because oil is dumping over relief.

Instructions for converting valve to open center:

1. Widen left side of rake using left frame width switch on control box (Remember to be moving forward or rearward when doing this).
2. Release all pressure in hydraulic system (Shut tractor OFF and remove ignition Key).
3. Support valve bottom.
4. Remove left mounting bolt.
5. Remove 3 tie rod nuts on tank port (the outward side of valve).
6. Remove end cap, (do not loose the o-rings that are between the sections).
7. Remove plug in end cap with allen wrench, (save for future use).
8. Re-Assemble end cap and mounting angle, (torque tie rod nuts to 140 in.lbs. (16 N-M).
9. Install bolt in mounting angle.